

Inside a milk-processing plant

While there are differences among milk-processing facilities, many will resemble what you will see in this video. A truck picks up milk from the tanks on the farms and delivers the raw milk at the plant's receiving bay. After a quick inspection for some contaminants and residues, the milk continues through the facility for processing.



Sunrise Milk

A-Receiving bay

B-Filter

C-Chiller

D-Storage silos

E-Blending tank

F-Homogenizer

G-Vitamin addition

H-Pasteurizer

I - Pasteurized
product storage

J - Packaging/filler

K-Cold room

L - Shipping dock

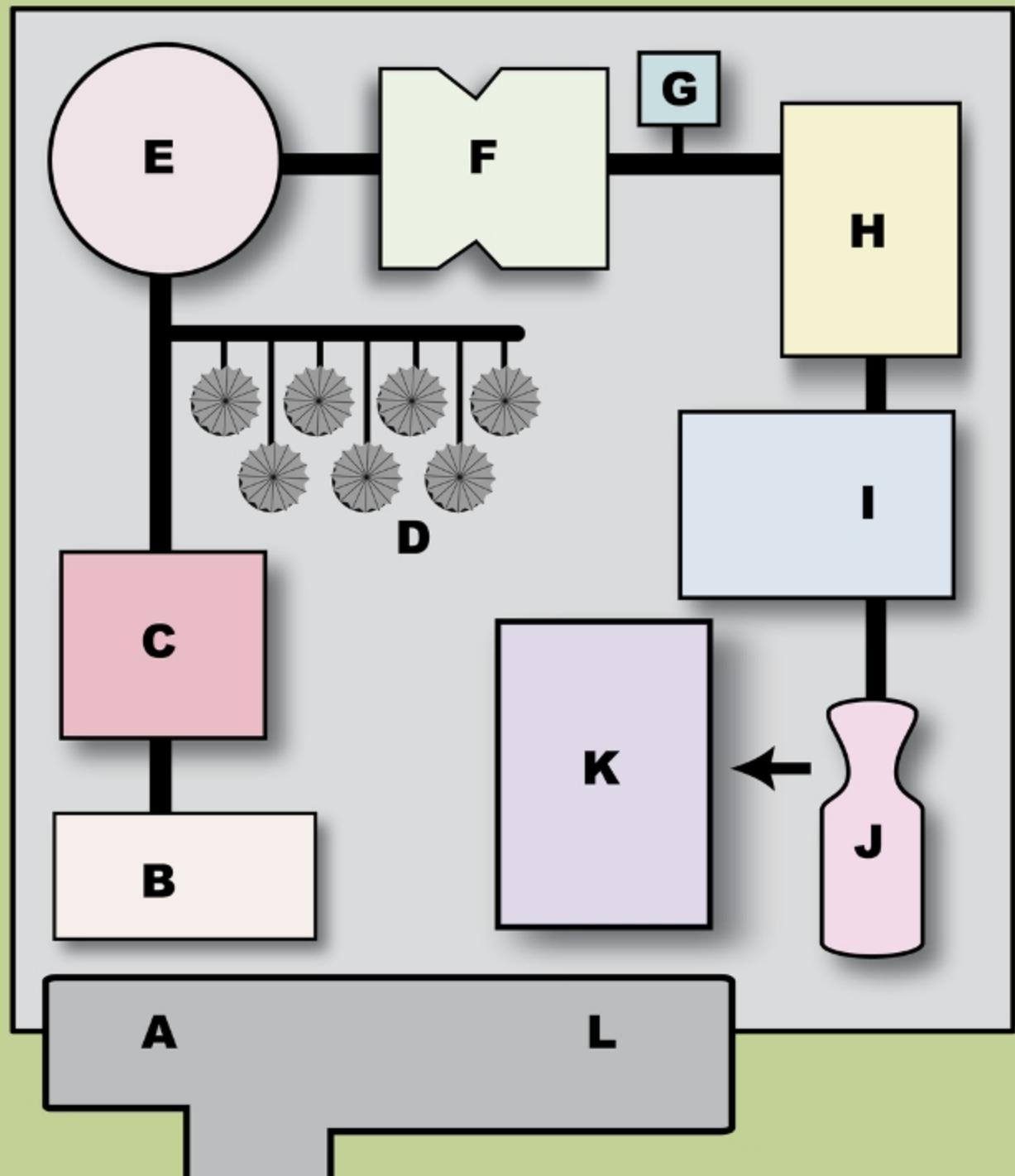

Sunrise Milk

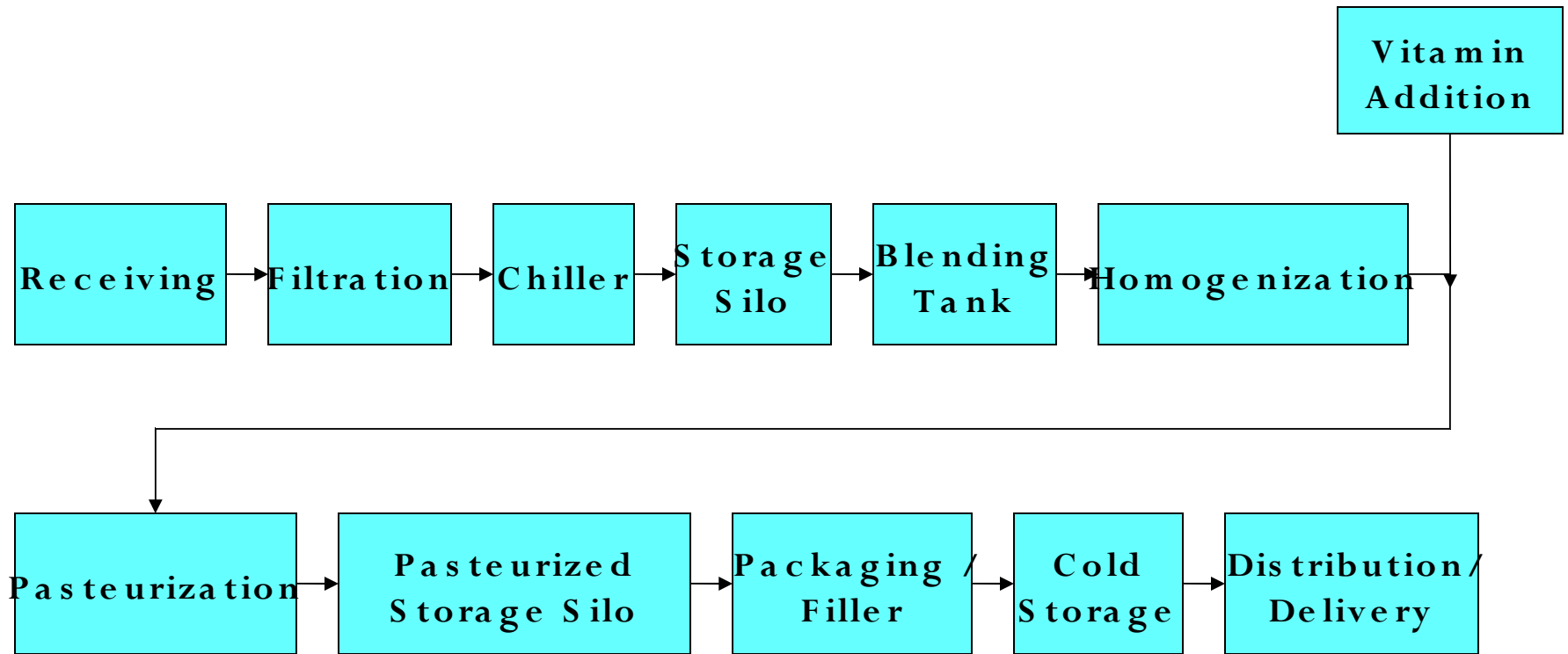

Video - Sunrise Milk Facility

